

ROAD BARRIERS VE.650



- Electromechanical road barrier for passages up to 6,5 m, intensive use with great performances
- Safety guaranteed by low voltage
- Easy installation and programming of the barrier
- Stainless steel version available
- Possibility of integrated FTC.S photocells thanks to the innovative hide-away system that enables them to be perfectly integrated with the look, ensuring maximum functionality

**Equipped with
foundation plate**

**The standard road barriers
are equipped with 2
neutral springs**



VE.650



Sturdy and compact operator for maximum reliability and long life



Built-in control panel with fast and easy programming

NOTES:

.....

.....

.....

.....

.....

.....

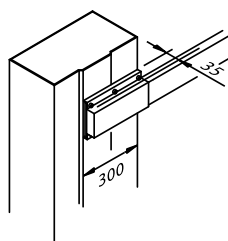
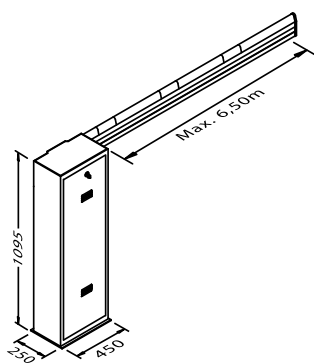

VE.P650

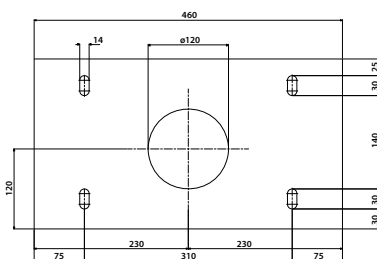

HOW TO CHOOSE THE TYPE OF SPRING AND THE POSSIBLE ACCESSORIES

CODE	TYPE OF SPRING	LENGHT OF ROAD BARRIER BEAM (m)	THE POSSIBLE ACCESSORIES
VE.650/1	1 neutral	4,5	VE.AM - SC.RES - VE.L650 - VE.RAST - VE.RP
	1 yellow + 1 neutral	5	VE.AM - SC.RES - VE.L650 - VE.RAST - VE.RP
	1 yellow + 1 neutral	5,5	VE.AM - SC.RES - VE.L650 - VE.RAST - VE.RP
	1 yellow + 1 neutral	6	-
	2 neutral	6	VE.AM - SC.RES - VE.L650 - VE.RAST - VE.RP
	2 neutral	6,5	VE.AM - SC.RES - VE.L650 - VE.RAST - VE.RP

TECHNICAL DATA

	VE.650	VE.650I
Power supply	230 Vac	230 Vac
Motor supply	24 Vdc	24 Vdc
Max. Absorbed current	1,6 A	1,6 A
Torque	285 Nm	285 Nm
Opening speed	5"-7"	5"-7"
Operation cycle	intensive use	intensive use
Protection level	IP 44	IP 44
Operating Temp.	-20°C/+50°C	-20°C/+50°C
Weight	83,6 Kg	83,6 Kg
Items no. per pallet	6	6